



CRAFTSMAN Double Rack Oven

Bakery



Features & Benefits

Craftsman[®]

- Rack lift or platform options
- Electric lifting device (on hook models)
- 99 program CPU controller
- Interior light
- 2 single racks per bake
- Electrical or fuel execution
- 500mm canopy
- Selectable oven vent & steam extraction system

MOFFAT®

CRAFTSMAN Double Rack Oven

TECHNICAL DATA

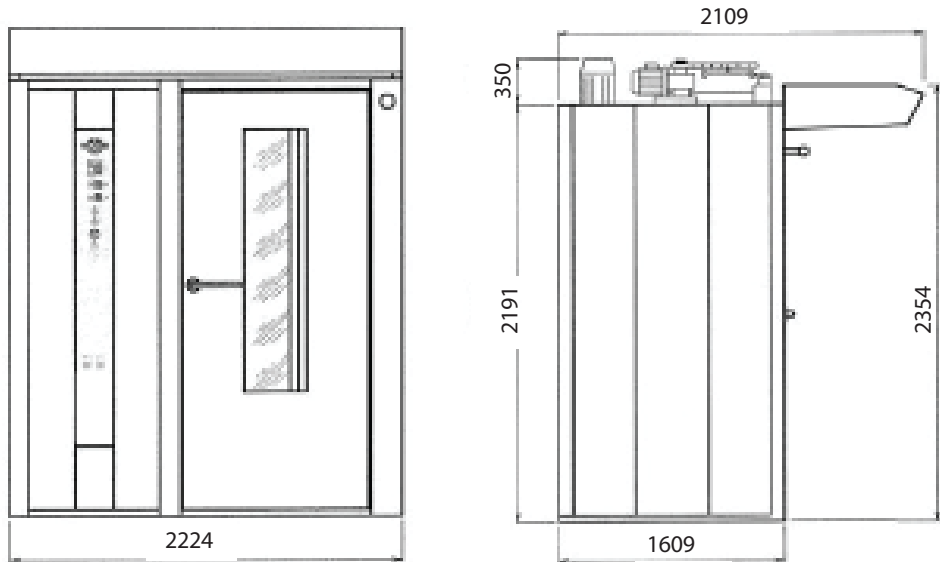

OVERALL DIMENSIONS: 2224mm wide x 2541mm high x 2109mm deep (inc. Canopy)
Dimensions EXCLUDE all protrusions (door handles, drains etc)

Technical Specifications

ARTR02

Electric

Gas

Power Rating	78kW / 110 amps per phase	97kW Burner - 3kW Electrical
Supply Voltage	400 - 415V, 50Hz, 3P + N + E	400 - 415V, 50Hz, 3P + N + E
Weight	1733kg	1816kg

Minimum Floor to ceiling Height For Installation - 2900mm

Approx. capacity per bake

Rack options

Rolls	900	ARTRRS10 - 10 Shelf
Loaves	120	ARTRRS15 - 15 Shelf
Pies	540	ARTRRS25 - 25 Shelf

In line with policy to continually develop and improve its products, Moffat reserves the right to change specifications and design without notice.

National Sales Hotline

Toll Free 1800 023 953

Melbourne

740 Springvale Road
Mulgrave, Victoria 3170
Telephone (613) 9518 3888
Facsimile (613) 9518 3833
Email: vsales@moffat.com.au

Sydney

Telephone (612) 8833 4111
Facsimile (612) 8833 4122
Email: nswsales@moffat.com.au

Perth

Telephone (618) 9202 6820
Email: vsales@moffat.com.au

Adelaide

Telephone 1800 023 953
Facsimile (613) 9518 3833
Email: vsales@moffat.com.au

Brisbane

Telephone (617) 3630 8600
Facsimile (617) 3630 8623
Email: qldsales@moffat.com.au

Christchurch, New Zealand

Telephone (643) 389 1007
Facsimile (643) 389 1276
Email: sales@moffat.co.nz
Web: www.moffat.co.nz

Auckland, New Zealand

Telephone (649) 574 3150
Facsimile (649) 574 3159
Email: sales@moffat.co.nz
Web: www.moffat.co.nz

National 24 Hour Service Hotline

(Australia Wide)
Toll Free 1800 622 216

Replacement Parts

(Australia Wide)
Toll Free 1800 337 963



MOFFAT®

www.moffat.com.au