

Technical data sheet for

3 DECK 1 SPLIT SLIMLINE ROTEL 18" TRAY VERSION

Model Number SR3D1S18

- Each chamber individually controlled
- Live inbuilt steaming system fitted to all chambers
- Control panel centrally mounted
- All instrumentation recessed and guarded
- Bake timers fitted to all chambers
- Interior lamps fitted standard to all chambers
- Tempered glass panels in doors as standard 10mm thick



Overall Construction

- Internal baking chambers stainless steel
- Facia & doors stainless steel
- Side and rear of oven colorbond cladding
- Tray holders welded steel and fitted standard to all split decks
- Turntable drive system top mounted
- Casters fitted as standard

Operation

- Temperature controller fitted 0 – 400°C
- Timer 0 – 60 minutes
- Dual control steam duration – high & low settings
- Top & bottom element control to standard decks
- Balance control fitted to all spit decks and offset split decks
- Steam ducting/venting fitted to all chambers
- Turntable rotation drive has independent switch

* It is advisable that water quality/supply be tested by the purchaser to ensure incoming water supply does not require additional filtration systems. Sites with high mineral deposits or hard water supply will require additional filtration and failure to fit these where required can result in oven deterioration/corrosion/rusting/and incorrect solenoid operation, all of which are not covered under warranty conditions offered by Moffat Pty Ltd.

Rotel 2®

Technical data sheet for

3 DECK 1 SPLIT SLIMLINE ROTEL 18" TRAY VERSION

Model Number SR3D1S18

Oven Configuration / Capacity

- Top deck - Standard deck
(2 chambers/2 tray capacity each chamber)
- Middle deck - Standard split deck
(2 chambers/4 tray capacity each chamber)
- Bottom deck - Standard deck
(2 chambers/2 tray capacity each chamber)
- Total tray capacity of oven 16 trays 18" x 29"
- Total loaf capacity of oven 108 x 680 gram loaves

Specifications

- W 2870mm x D 1505mm x H 2210mm (uncrated)
- 400 - 415V, 3P+N+E, 50Hz, 45kW
- Water connection ½" centre rear
- Supplied with 2 metre stainless steel flexible hose
- 20 micron water filter supplied
(requires fitting by others)
- Oven requires direct wiring by others
- Oven supply does not include canopies and flues
as required by relevant authorities
- Recommended minimum ceiling height required
for servicing purposes 2710mm
- Weight 1500kg

Additional Technical Information

- Usable crown height - Standard decks 200mm
- Usable crown height - Standard split decks
170mm lower - 170mm top
- Usable crown height - Offset split decks
110mm lower - 190mm top
- Maximum recommended operating temperature
of oven 270°C

Options

- Steel plates or ceramic soles for sole bread baking
- High crowns up to 300mm (only available some models)

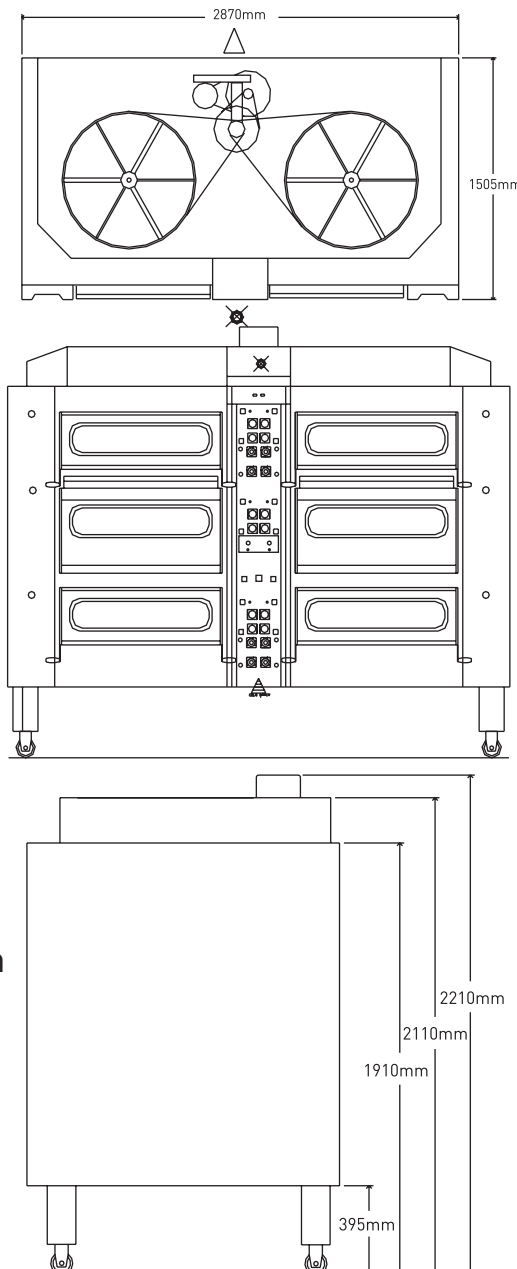

Australia
Moffat Pty Limited

Victoria / Tasmania
740 Springvale Rd
Mulgrave
Victoria 3170
Australia
Ph 03-9518 3888
Fax 03-9518 3833
Email vsales@moffat.com.au
www.moffat.com.au

New South Wales
Ph 02-8833 4111
Email nswsales@moffat.com.au
www.moffat.com.au

South Australia
Ph 03-9518 3888
Email vsales@moffat.com.au
www.moffat.com.au

Queensland
Ph 07-3630 8600
Email qldsales@moffat.com.au
www.moffat.com.au

Western Australia
Ph 08-9202 6820
Email bgarcia@moffat.com.au
www.moffat.com.au

New Zealand
Moffat Limited

Christchurch
16 Osborne Street
Christchurch 8011
New Zealand
Ph 03-389 1007
Fax 03-389 1276
Email sales@moffat.co.nz
www.moffat.co.nz

Auckland
Ph 09-574 3150
Email sales@moffat.co.nz
www.moffat.co.nz



In line with policy to continually develop
and improve its products, Moffat Limited
reserves the right to change
specifications and design without notice.

Printed in China
© Copyright Moffat Ltd

Moffat/6244/BH/2.08

