

Technical data sheet for

## ROBOT D-20 AUTOMATIC DOUGH DIVIDER - 20 PIECE

Model Number ROBOCUT2-R20

- 20 dough pieces per operation
- Positive lid lock system
- Pressing and cutting functions fully automatic
- Push button controls (front mounted)
- Machine fitted with auto blade raise system to facilitate cleaning (front mounted)
- Fitted standard with power isolation switch (side mounted)



### Overall Construction

- Extended base designed to protect machine from rack damage
- Heavy-duty steel fabricated body construction for durability and long life
- Machine base and body in two-pack paint finish
- Positive lid locking system
- Fitted with nylon wheels as standard
- Stainless steel internal cylinder
- Teflon coated pressing plate for easy cleaning

### Operation

- Automatic pressing/degassing
- Automatic cutting of dough
- Button operation (front mounted)
- Finished weights determined by bulk dough placed in cylinder
- Minimum recommended dough capacity per operation 4kg
- Maximum recommended dough capacity per operation 16kg

Note: Maximum dough capacity of machine can vary depending on condition of dough and strength of flour being used



Technical data sheet for

## ROBOT D-20 AUTOMATIC DOUGH DIVIDER - 20 PIECE

Model Number ROBOCUT2-R20

### Machine Weight Range / Output

- Minimum weight range 200 gram dough pieces
- Maximum weight range 800 gram dough pieces
- Output approx 1200 pieces per hour

### Specifications

- W 620mm x D 620mm x H 1120mm (including locking handle)
- 400 – 415V, 3P+N+E, 50Hz, 1.1kW
- 5 pin 10A plug supplied
- Weight 360kg

### Additional Technical Information

- Internal chamber dimensions 470mm x 110mm
- Power outlet to be located a minimum 1.5m off floor

### Options

- Machines available with various weight ranges to suit specialized production needs

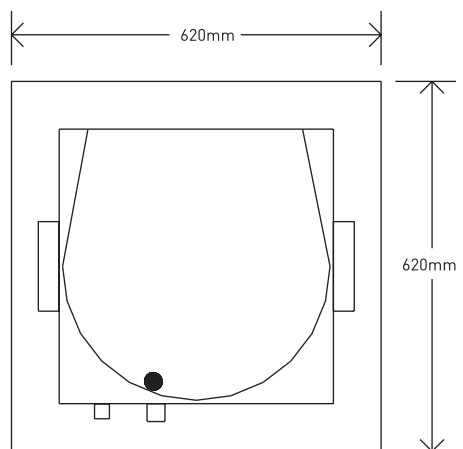
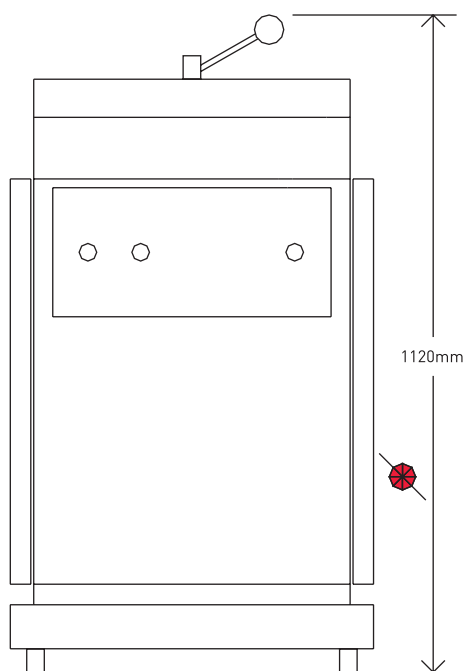

Australia  
Moffat Pty Limited

Victoria / Tasmania  
740 Springvale Rd  
Mulgrave  
Victoria 3170  
Australia  
Ph 03-9518 3888  
Fax 03-9518 3833  
Email [vsales@moffat.com.au](mailto:vsales@moffat.com.au)  
[www.moffat.com.au](http://www.moffat.com.au)

New South Wales  
Ph 02-8833 4111  
Email [nswsales@moffat.com.au](mailto:nswsales@moffat.com.au)  
[www.moffat.com.au](http://www.moffat.com.au)

South Australia  
Ph 03-9518 3888  
Email [vsales@moffat.com.au](mailto:vsales@moffat.com.au)  
[www.moffat.com.au](http://www.moffat.com.au)

Queensland  
Ph 07-3630 8600  
Email [qldsales@moffat.com.au](mailto:qldsales@moffat.com.au)  
[www.moffat.com.au](http://www.moffat.com.au)

Western Australia  
Ph 08-9202 6820  
Email [bgarcia@moffat.com.au](mailto:bgarcia@moffat.com.au)  
[www.moffat.com.au](http://www.moffat.com.au)

New Zealand  
Moffat Limited

Christchurch  
16 Osborne Street  
Christchurch 8011  
New Zealand  
Ph 03-389 1007  
Fax 03-389 1276  
Email [sales@moffat.co.nz](mailto:sales@moffat.co.nz)  
[www.moffat.co.nz](http://www.moffat.co.nz)

Auckland  
Ph 09-574 3150  
Email [sales@moffat.co.nz](mailto:sales@moffat.co.nz)  
[www.moffat.co.nz](http://www.moffat.co.nz)



In line with policy to continually develop and improve its products, Moffat Limited reserves the right to change specifications and design without notice.

Printed in China  
© Copyright Moffat Ltd

Moffat/6244/BH/2.08

