

Technical data sheet for

## 3 DECK 3 SPLIT MINI ROTEL 18" TRAY VERSION

Model Number R1218

- Each chamber individually controlled
- Live inbuilt steaming system fitted to all chambers
- Control panel positioned right hand side front
- Instrumentation recessed and guarded
- Bake timers fitted to all chambers
- Interior lamps fitted standard to all chambers
- Tempered glass panels in doors as standard 10mm thick



### Overall Construction

- Internal baking chambers stainless steel
- Facia & doors stainless steel
- Side and rear of oven colorbond cladding
- Tray holders welded steel and fitted standard to all split decks
- Turntable drive system top mounted
- Casters fitted as standard

### Operation

- Temperature control range 0 - 400°C
- Bake timer 0 - 60 minutes
- Fixed steam duration
- Top & bottom element control to standard decks
- Balance control fitted to all spit decks and offset split decks
- Steam venting/ducting to all chambers

\* It is advisable that water quality/supply be tested by the purchaser to ensure incoming water supply does not require additional filtration systems. Sites with high mineral deposits or hard water supply will require additional filtration and failure to fit these where required can result in oven deterioration/corrosion/rusting/and incorrect solenoid operation, all of which are not covered under warranty conditions offered by Moffat Pty Ltd.

# Rotel 2.

Technical data sheet for

## 3 DECK 3 SPLIT MINI ROTEL 18" TRAY VERSION

Model Number R1218

### Oven Configuration / Capacity

- Top deck - Offset split (1 chamber/4 tray capacity)
- Middle deck - Standard split deck (1 chamber/4 tray capacity)
- Bottom deck - Standard split deck (1 chamber/4 tray capacity)
- Total baking tray capacity of oven 12 trays 18" x 29"
- Total loaf capacity of oven 60 x 680 gram loaves

### Specifications

- W 1490mm x D 1505mm x H 2195mm (uncrated)
- 400 - 415V, 3P+N+E, 50Hz, 30kW
- Water connection ½" left hand rear
- Supplied with 2 metre stainless steel flexible hose
- 20 micron water filter supplied (requires fitting by others)
- Oven requires direct wiring by others
- Oven supply does not include canopies and flues as required by relevant authorities
- Recommended minimum ceiling height required for servicing purposes 2695mm
- Weight 1020kg

### Additional Technical Information

- Usable crown height - Standard decks 200mm
- Usable crown height - Standard split decks 170mm lower - 170mm top
- Usable crown height - Offset split decks 110mm lower - 190mm top
- Maximum recommended operating temperature rating 270°C

### Options

- Steel plates or ceramic soles for sole bread baking
- High crown up to 300mm (only available some models)

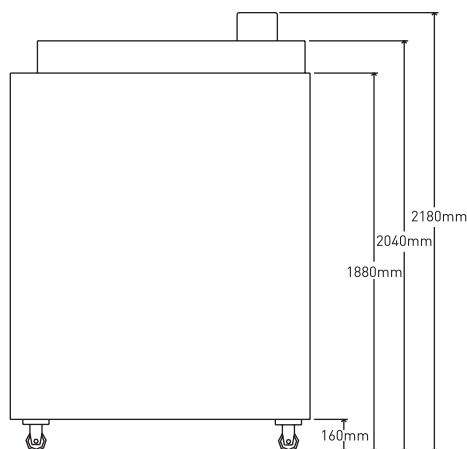
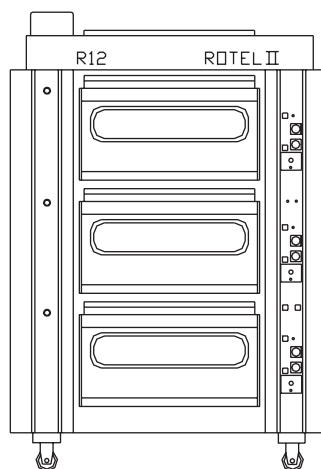
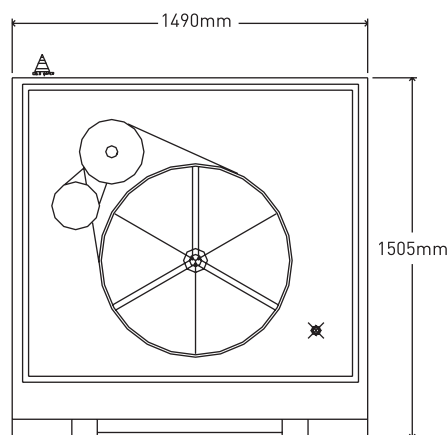

Australia  
Moffat Pty Limited

Victoria / Tasmania  
740 Springvale Rd  
Mulgrave  
Victoria 3170  
Australia  
Ph 03-9518 3888  
Fax 03-9518 3833  
Email [vsales@moffat.com.au](mailto:vsales@moffat.com.au)  
[www.moffat.com.au](http://www.moffat.com.au)

New South Wales  
Ph 02-8833 4111  
Email [nswsales@moffat.com.au](mailto:nswsales@moffat.com.au)  
[www.moffat.com.au](http://www.moffat.com.au)

South Australia  
Ph 03-9518 3888  
Email [vsales@moffat.com.au](mailto:vsales@moffat.com.au)  
[www.moffat.com.au](http://www.moffat.com.au)

Queensland  
Ph 07-3630 8600  
Email [qldsales@moffat.com.au](mailto:qldsales@moffat.com.au)  
[www.moffat.com.au](http://www.moffat.com.au)

Western Australia  
Ph 08-9202 6820  
Email [bgarcia@moffat.com.au](mailto:bgarcia@moffat.com.au)  
[www.moffat.com.au](http://www.moffat.com.au)

New Zealand  
Moffat Limited

Christchurch  
16 Osborne Street  
Christchurch 8011  
New Zealand  
Ph 03-389 1007  
Fax 03-389 1276  
Email [sales@moffat.co.nz](mailto:sales@moffat.co.nz)  
[www.moffat.co.nz](http://www.moffat.co.nz)

Auckland  
Ph 09-574 3150  
Email [sales@moffat.co.nz](mailto:sales@moffat.co.nz)  
[www.moffat.co.nz](http://www.moffat.co.nz)



In line with policy to continually develop and improve its products, Moffat Limited reserves the right to change specifications and design without notice.

Printed in China  
© Copyright Moffat Ltd

Moffat/6244/BH/2.08

