

## Technical data sheet for **CONVOTHERM OES 12.20**

### General features:

- Advanced Closed System (for detailed information, see reverse)
- Stainless steel construction
- Height-adjustable feet 230 - 250 mm
- Anti-wear door contact switch
- Oven has rounded corners
- Pivoting removable suction plate
- Hygienic plug-in gasket for day-to-day cleaning, easy to remove
- Self-emptying condensate drip tray
- Oven light with shock-resistant glass cover
- Permanent self-diagnosis for error recognition
- System with full-text error description
- Emergency programme mode: appliance operates with limited functionality even when technical defects arise
- Detailed documentation, spare parts lists, circuit diagrams in appliance
- Injector version
- incl. trolley (easy course roll Ø 125 mm)

### Standard features:

- Disappearing door
- Multi-point core temperature sensor
- Fan with auto-reverse
- Reduced fan speed for cooking sensitive products (programmable)
- CONVOTHERM Cookbook with pre-programmed recipes
- Butterfly valve: less steam escapes when oven door is opened
- Hand shower with continuously variable setting
- Door rotary lever lock with raised position, supplementary function and safety function
- Seamlessly welded high-shine oven chamber
- Left to right shelf loading (2/1 GN)
- Double glass door with integrated lock position and self-emptying condensate drip tray
- Module-based processor control with plain text display and module auto-control
- Crisp&Tasty (demoisturising in closed system with several levels)
- Auxiliary timer
- Reduced heat output for operating at peak periods (programmable)
- Easy to operate with menus/icons
- Bright graphic display
- Digital dial makes it easy to set temperature, time and core temperature
- Pre-set start time in real-time mode
- Programme in 250 recipes of up to 20 steps each
- Cook & Hold and Delta-T cooking
- RS 232 interface
- Can be connected up to energy optimisation unit
- Programme protection (prevents programmes in progress from being interrupted through energy optimisation unit)
- Save all settings and recipes in additional memory module (identity module)

### Optional features:

- CONVOClean system (automatic cleaning programme)
- Press&Go (symbol)
- PC-HACCP software for fully automated documentation and archiving of cooking processes
- PC-Control software manages up to 31 CONVOTHERM combi steamers
- RS 232, RS 485 and USB communication modules to network up to 31 CONVOTHERM combi steamers
- RS 232, RS 485 and USB communication modules plus Ethernet to network up to 31 CONVOTHERM combi steamers and for Internet connection
- Version for ships, version for prisons
- Special voltages
- Baking area 600x400 mm



### Cooking programmes

**Steaming at** 30°C-120°C



- For steaming, stewing and poaching.

**Superheated steam** 100°C-250°C



- For roasting and baking.

**Convection** 30°C-250°C



- For grilling, quick roasting, baking, toasting and gratinating.

**Regeneration** 120°-160°C



- For fast heating of prepared dishes pre-arranged on the plate or platter.

### Optional Accessories

- Plated banqueting system
- Thermal cover
- Chicken set
- Baking sheets
- Pre-heat bridge
- CONVOClean forte (oven cleaner)
- CONVOCare neutralising cleaner



**CONVOTHERM®**

# Technical data sheet for CONVOTHERM OES 12.20

## Dimensions

Width (mm)	1232
Depth (mm)	1055
Height (mm)	1416
Weight (kg)	325*
*incl. trolley	

## Packed Dimensions

Width (mm)	1443
Depth (mm)	1198
Height (mm)	1649
Weight (kg)	380*
*incl. trolley	

## Shelves

1/1 GN	24
2/1 GN	12
Shelf spacing (mm)	67

Baking area 600x400	11
Shelf spacing (mm) 600x400	80

## Plated banqueting system

Number of plates	74
------------------	----

Latent heat kJ/h*	21384
Sensitive heat kJ/h*	14256
*calculated according to VDI 2052	

## Advanced Closed System

- with automatically regulated steam injection
- no manual input of moisture levels required
- no waiting time for cooling off
- switch immediately to any steam programme even at oven temperatures over 100°C
- low water and energy consumption
- Crisp&Tasty for perfect results
- no negative effect on air in the kitchen during the cooking process

## Installation conditions

(for precise installation instructions, please refer to our installation manual)

Power connection requirements  
AC connection  
Multi-pin circuit breaker, effective separator installed near appliance and supply line  
Voltage 380-415V~ 50/60 Hz, 3P+N+E

Special voltage options  
220-240V~ 50/60Hz, 3P+E  
400V~ 50/60Hz, 3P+E  
440V~ 60Hz, 3P+E

Installation conditions (customer premises)

Power connection  
Power connection  
Connection value (kW) 34,2  
Convection power output (kW) 33  
Rated current [A] 47,6

IPX 5 spray-proof and hose-proof.

For connection value, voltage and fuse rating, refer also to the circuit diagram.

## Installation distance from wall

- rear	50 mm
- right	75 mm
- left	100 mm

If heat sources are located near the combi steamer, ensure that an adequate safe distance is maintained.

**Install in accordance with local body regulations** only on horizontal surfaces and not against combustible walls.

## Water connection requirements

(\*Water softener may be required. Please refer to installation manual for water treatment values.)

- cold water
- flow pressure (2 to 6 bar)
- soft water connection\*
- shut-off valve with return flow inhibitor and dirt filter
- water supply (R3/4) with 1/2" pressure pipe
- backflow prevention valve (supplied)
- R50 waste water connection

Workplace-specific sound emission value

< 70 dB

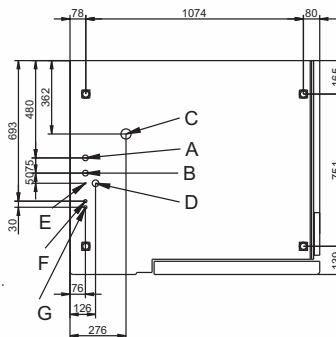
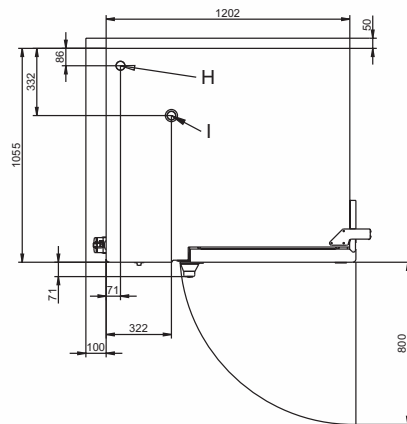
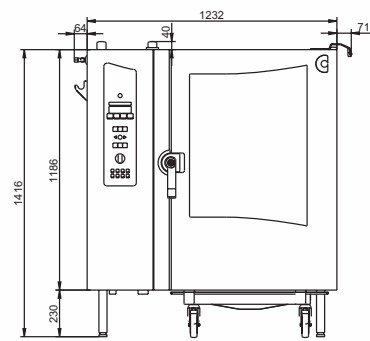

- A = R<sup>3</sup>/<sub>4</sub> soft water supply connection
- B = R<sup>3</sup>/<sub>4</sub> cold water supply connection
- C = R50 waste water connection
- D = Power connection
- E = Equipotential earth connection
- F = Clear rinse connection
- G = Cleaner connection
- H = Vent pipe
- I = Low-pressure failsafe device



**MOFFAT**

Australia  
[www.moffat.com.au](http://www.moffat.com.au)

New Zealand  
[www.moffat.co.nz](http://www.moffat.co.nz)



Printed in China

Australia  
Moffat Pty Limited

Victoria/Tasmania  
740 Springvale Road  
Mulgrave, Victoria 3170  
Telephone 03-9518 3888  
Facsimile 03-9518 3833  
Email [vsales@moffat.com.au](mailto:vsales@moffat.com.au)  
[www.moffat.com.au](http://www.moffat.com.au)

New South Wales  
Telephone 02-8833 4111  
Email [nswsales@moffat.com.au](mailto:nswsales@moffat.com.au)

South Australia  
Telephone 03-9518 3888  
Email [vsales@moffat.com.au](mailto:vsales@moffat.com.au)

Queensland  
Telephone 07-3630 8600  
Email [qldsales@moffat.com.au](mailto:qldsales@moffat.com.au)

Western Australia  
Telephone 08-9202 6820  
Email [bgarcia@moffat.com.au](mailto:bgarcia@moffat.com.au)

New Zealand  
Moffat Limited

Christchurch  
Telephone 03-389 1007  
Email [sales@moffat.co.nz](mailto:sales@moffat.co.nz)  
[www.moffat.co.nz](http://www.moffat.co.nz)

Auckland  
Telephone 09-574 3150  
Email [sales@moffat.co.nz](mailto:sales@moffat.co.nz)

In line with policy to continually develop and improve its products, Moffat Limited reserves the right to change specifications and design without notice.  
© Copyright Moffat Ltd

Moffat/6243-OES 12-20/BH/6M/01.08

