

Technical data sheet for **CONVOTHERM OEB 20.10**

General features:

- Advanced Closed System (for detailed information, see reverse)
- Stainless steel construction
- Height-adjustable feet 230 - 250 mm
- Anti-wear door contact switch
- Steam generator is automatically ready to operate, low-maintenance, electronic water level check and dry heat protection
- Oven has rounded corners
- Pivoting removable suction plate
- Hygienic plug-in gasket for day-to-day cleaning, easy to remove
- Self-emptying condensate drip tray
- Oven light with shock-resistant glass cover
- Permanent self-diagnosis for error recognition
- System with full-text error description
- Emergency programme mode: operate the appliance with limited functionality even when technical defects arise
- Detailed documentation, spare parts lists, circuit diagrams in appliance
- Steam generator version
- incl. trolley (easy course roll Ø 125 mm)

Standard features:

- Disappearing door
- Multi-point core temperature sensor
- Fan with auto-reverse
- Reduced fan speed for cooking sensitive products (programmable)
- CONVOTHERM Cookbook with pre-programmed recipes
- Butterfly valve: less steam escapes when oven door is opened
- Hand shower with continuously variable setting
- Automatic flushing of steam generator
- Door rotary lever lock with raised position, supplementary function and safety function
- Seamlessly welded high-shine oven chamber
- Lengthwise shelf loading (1/1 GN)
- Double glass door with integrated lock position and self-emptying condensate drip tray
- Module-based processor control with plain text display and module auto-control
- Press&Go (symbol)
- Crisp&Tasty (demoisturising in closed system with several levels)
- Auxiliary timer
- Easy to operate with menus/icons
- Bright graphic display
- Digital dial makes it easy to set temperature, time and core temperature
- Pre-set start time in real-time mode
- Programme in 250 recipes of up to 20 steps each
- Cook & Hold and Delta-T cooking
- Reduced heat output for operating at peak periods (programmable)
- RS 232 interface
- Can be connected up to energy optimisation unit
- Programme protection (prevents programmes in progress from being interrupted through energy optimisation unit)
- Save all settings and recipes in additional memory module (identity module)

Optional features:

- CONVOClean system (automatic cleaning programme)
- PC-HACCP software for fully automated documentation and archiving of cooking processes
- PC-Control software manages up to 31 CONVOTHERM combi steamers
- RS 232, RS 485 and USB communication modules to network up to 31 CONVOTHERM combi steamers
- RS 232, RS 485 and USB communication modules plus Ethernet to network up to 31 CONVOTHERM combi steamers and for Internet connection
- Version for ships, version for prisons
- Special voltages
- Baking area 600x400 mm



Cooking programmes

Steaming at 30°C-120°C

- For steaming, stewing and poaching.



Superheated steam 100°C 250°C

- For roasting and baking.



Convection 30°C-250°C

- For grilling, quick roasting, baking, toasting and gratinating.



Regeneration 120°-160°C

- For fast heating of prepared dishes pre-arranged on the plate or platter.



Optional Accessories

- Plated banqueting system
- Thermal cover
- Chicken set
- Baking sheets
- Pre-heat bridge
- CONVOClean forte (oven cleaner)
- CONVOCare neutralising cleaner



CONVOTHERM®

Technical data sheet for CONVOTHERM OEB 20.10

Dimensions

Width (mm)	947
Depth (mm)	855
Height (mm)	1952
Weight (kg)	340*
*incl. trolley	

Packed Dimensions

Width (mm)	1148
Depth (mm)	998
Height (mm)	2185
Weight (kg)	400*
*incl. trolley	

Shelves

1/1 GN	20
2/1 GN	-
Shelf spacing (mm)	67

Baking area 600x400	on request
Shelf spacing (mm) 600x400	80

Plated banqueting system

Number of plates	61
Latent heat kJ/h*	24494
Sensitive heat kJ/h*	16330
*calculated according to VDI 2052	

Advanced Closed System

- with automatically regulated steam injection
- no manual input of moisture levels required
- no waiting time for cooling off
- switch immediately to any steam programme even at oven temperatures over 100°C
- low water and energy consumption
- Crisp&Tasty for perfect results
- no negative effect on air in the kitchen during the cooking process

Installation conditions

(for precise installation instructions, please refer to our installation manual)

Power connection requirements
AC connection
Multi-pin circuit breaker, effective separator installed near appliance and supply line
Voltage 380-415V~ 50/60 Hz, 3P+N+E

Special voltage options
220-240V~ 50/60Hz, 3P+E
400V~ 50/60Hz, 3P+E
440V~ 60Hz, 3P+E

Installation conditions (customer premises)

Power connection
Connection value (kW) 39,7
Convection power output (kW) 37,8
Steam generator power output (kW) 29,7
Rated current [A] 52,8

IPX5 spray-proof and hose-proof.

For connection value, voltage and fuse rating, refer also to the circuit diagram.

Installation distance from wall

- rear	50 mm
- right	75 mm
- left	100 mm

If heat sources are located near the combi steamer, ensure that an adequate safe distance is maintained.

Install in accordance with local body regulations only on horizontal surfaces and not against combustible walls.

Water connection requirements

(*Water softener may be required. Please refer to installation manual for water treatment values.)

- cold water
- flow pressure (2 to 6 bar)
- soft water connection*
- shut-off valve with return flow inhibitor and dirt filter
- water supply (R3/4) with 1/2" pressure pipe
- backflow prevention valve (supplied)
- R50 waste water connection

Workplace-specific sound emission value

< 70 dB

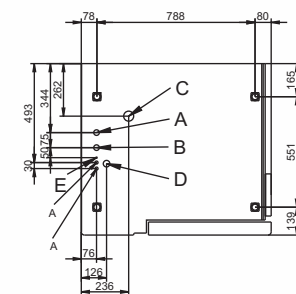
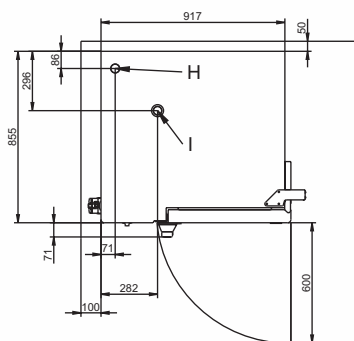
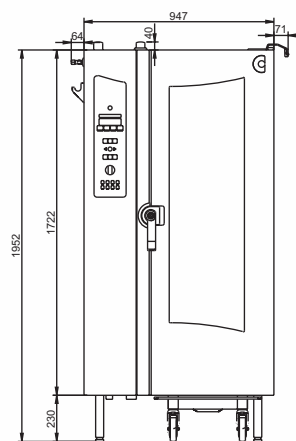

- A = R³/₄ soft water supply connection
- B = R³/₄ cold water supply connection
- C = R50 waste water connection
- D = Power connection
- E = Equipotential earth connection
- F = Clear rinse connection
- G = Cleaner connection
- H = Vent pipe
- I = Low-pressure failsafe device



MOFFAT®

Australia
www.moffat.com.au

New Zealand
www.moffat.co.nz



Printed in China

Australia
Moffat Pty Limited
Victoria/Tasmania
740 Springvale Road
Mulgrave, Victoria 3170
Telephone 03-9518 3888
Facsimile 03-9518 3833
Email vsales@moffat.com.au
www.moffat.com.au

New South Wales
Telephone 02-8833 4111
Email nswsales@moffat.com.au

South Australia
Telephone 03-9518 3888
Email vsales@moffat.com.au

Queensland
Telephone 07-3630 8600
Email qldsales@moffat.com.au

Western Australia
Telephone 08-9202 6820
Email bgarcia@moffat.com.au

New Zealand
Moffat Limited

Christchurch
Telephone 03-389 1007
Email sales@moffat.co.nz
www.moffat.co.nz

Auckland
Telephone 09-574 3150
Email sales@moffat.co.nz

In line with policy to continually develop and improve its products, Moffat Limited reserves the right to change specifications and design without notice.

© Copyright Moffat Ltd

Moffat/6243-OEB 20-10/BH/6M/01.08

