

Technical data sheet for

SOTTORIVA FCL4 SPECIALTY BREAD ROLL MOULDER

Model Number FCL4

- Three separate selection settings (side located)
- Exit tables drop down when not in use
- Flat hamburger sheeting function
- In feed conveyor guarded for operator safety
- Fitted standard with power isolation switch (side mounted)

Overall Construction

- Heavy-duty steel fabricated body construction for durability and long life
- Machine body in two-pack paint finish
- 600 mm sheeting rollers finished in hardened chrome
- Fitted with nylon wheels as standard
- Clear see through guarding as standard

Operation

- Conveyor feed for high output
- Variable sheeting thickness selection
- Variable product length
- Fitted with green start and red stop as standard
- Emergency stop fitted
- Minimum recommended roll weight 30 grams
- Maximum recommended roll/baguette weight 200 grams

Note: Machine is not recommended for dough pieces/products with weight over 500 grams



Technical data sheet for

SOTTORIVA FCL4 SPECIALTY BREAD ROLL MOULDER

Model Number FCL4

Machine Weight Range / Output

- Recommended minimum weight range
35 gram dough pieces
- Recommended maximum weight range
350 gram dough pieces
- Output up to 720 rolls per hour at
100 grams (manual operation)
- Output above 120 grams – 360 dough pieces
per hour maximum

Specifications

- W 935mm x D 1168mm x H 1200mm
(Depth with in feed and exit tables upright)
- 400 – 415V, 3P+N+E, 50Hz, .75kW
- 5 pin 10A plug supplied
- Weight 208kg

Additional Technical Information

- Power outlet to be located a minimum 1.5m off floor

Options

- Above machines with pressing plate on a 900mm long
out feed belt (For automatic width extension of products
such as hot dog rolls and baguettes) Model C40/P

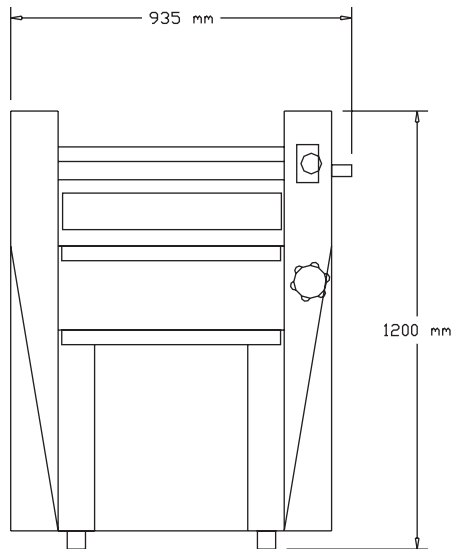
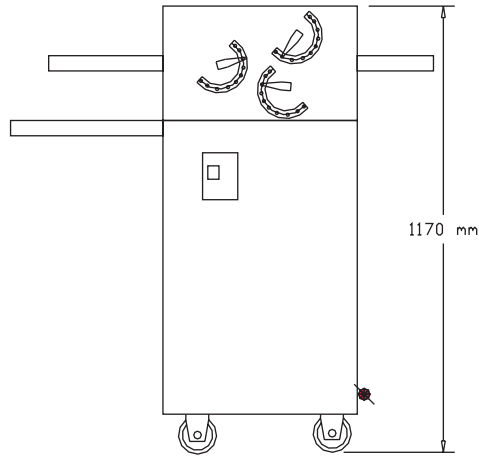
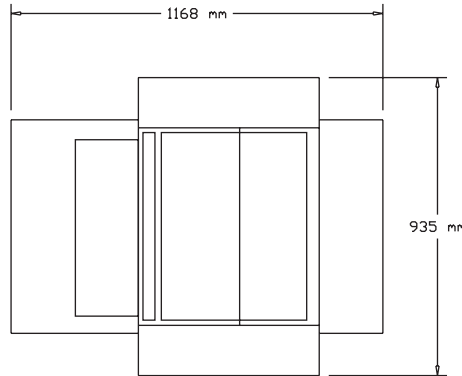

Australia
Moffat Pty Limited

Victoria / Tasmania
740 Springvale Rd
Mulgrave
Victoria 3170
Australia
Ph 03-9518 3888
Fax 03-9518 3833
Email vsales@moffat.com.au
www.moffat.com.au

New South Wales
Ph 02-8833 4111
Email nswsales@moffat.com.au
www.moffat.com.au

South Australia
Ph 03-9518 3888
Email vsales@moffat.com.au
www.moffat.com.au

Queensland
Ph 07-3630 8600
Email qldsales@moffat.com.au
www.moffat.com.au

Western Australia
Ph 08-9202 6820
Email bgarcia@moffat.com.au
www.moffat.com.au

New Zealand
Moffat Limited

Christchurch
16 Osborne Street
Christchurch 8011
New Zealand
Ph 03-389 1007
Fax 03-389 1276
Email sales@moffat.co.nz
www.moffat.co.nz

Auckland
Ph 09-574 3150
Email sales@moffat.co.nz
www.moffat.co.nz



In line with policy to continually develop and improve its products, Moffat Limited reserves the right to change specifications and design without notice.

Printed in China
© Copyright Moffat Ltd

Moffat/6244/BH/2.08

