

ELECTRIC COUNTER TILTING KETTLE



SPECIFICATIONS:

Shall be a CROWN Model _____, self-generating, electric, counter, tilting kettle. A double wall kettle interior shall form a steam jacket around the lower 2/3 of the kettle. The jacket enclosure shall contain distilled water which is factory sealed. The bottom of the kettle shall be of hemispherical design for superior heat circulation.

The stainless steel rectangular mounting base shall include the kettle mounting lugs concealed inside the enclosure.

A removable operating handle with heat proof knob shall be mounted on the right.

Construction shall be of all welded #4 finish stainless steel, type 304. The interior cooking surface shall be of type 316 stainless steel for added resistance to corrosion. The kettle shall be ASME Code stamped, National Board Registered, c-CSA-us and NSF certified.

The controls shall be water resistant, integrally mounted and shall include a power switch, solid state thermostat, pilot light, vacuum/pressure gauge, safety valve and low water shut off with low water light.

The kettle shall operate in a temperature range of 165°F to 285°F (74°C to 140°C) at a maximum pressure of 50 psi (345 kPa). The kettle shall be standard with removable elements.

Model	Capacities		
	kW	US Gal.	litres
EC-6TW	7.5	6	23
EC-10TW	12	10	38
EC-12TW	12	12	45

OPERATION SHALL BE BY:

Electrically, self-generating closed steam system equipped for operation on:

The kettle shall be equipped for operation on:

- 208 VAC, 1 or 3 phase, 50/60 Hz. *
- 220 VAC, 1 or 3 phase, 50/60 Hz. *
- 240 VAC, 1 or 3 phase, 50/60 Hz. *
- 415/240 VAC, 3 phase, 4 wire, 50/60 Hz.
- 380/220 VAC, 3 phase, 4 wire, 50/60 Hz.

* Phase is field convertible.

STANDARD FEATURES:

- ✓ Low water level cut-off and indicator.
- ✓ Pressure gauge.
- ✓ Solid state temperature control.
- ✓ Safety relief valve.
- ✓ Type 316 stainless steel liner.
- ✓ 2/3 steam jacket.
- ✓ 50 PSI (345 kPa) high pressure operation for higher cooking temperature.
- ✓ Integrally mounted controls.
- ✓ Removable elements.
- ✓ "Clean lock" to hold kettle in cooking position or 105° for ease of cleaning.
- ✓ Stainless steel console and trunnion.
- ✓ Water resistant construction.

OPTIONS AT EXTRA COST:

- 380 VAC, 3 phase, 50/60 Hz.
- 415 VAC, 3 phase, 50/60 Hz.
- 480 VAC, 3 phase, 50/60 Hz.
- 600 VAC, 3 phase, 50/60 Hz.
- Etched gallon markings (GM-).
- Etched litre markings (LM-).
- Correction package.

ACCESSORIES:

- One piece lift-off stainless steel cover (C-).
- Stainless steel perforated basket (SSB-).
- 18" high floor stand c/w sliding drain pan and stationary drain (SD-30).
- Graduated measuring strip (CMS-).
- Single pantry faucet with swing spout (SF-12).
- Double pantry faucet with swing spout (DF-12).
- Pour lip strainer (TKS-).



CROWN DETAILS AND DIMENSIONS

SERVICE CONNECTIONS

⚡ - ELECTRICAL CONNECTION TO BE AS SPECIFIED ON DATA PLATE

💧 - COLD WATER: 3/8" O.D. tubing to faucet (OPTIONAL)

🔥 - HOT WATER: 3/8" O.D. tubing to faucet (OPTIONAL)

ELECTRICAL CHARACTERISTICS

MODEL	kW	PHASE	AMPS PER LINE						
			208V	220V	240V	380V	415V	480V	600V
EC-6TW	7.5	1	36.0	34.1	31.3	N/A	N/A	N/A	N/A
		3	20.8	19.7	18.1	11.4	10.4	9.0	7.2
EC-10TW/12TW	12.0	1	57.6	54.6	50.0	N/A	N/A	N/A	N/A
		3	33.3	31.5	28.9	18.3	16.7	14.5	11.5

DIMENSIONS

MODEL	CAPACITY	UNITS	A	B	C	D	E	F	G	H	J	K	L
EC-6TW	6 gallons	inches	12	14.38	24	33.5	15.25	22.25	4.50	27	4.25	12.38	10
	23 litres	mm	305	365	610	851	387	565	114	686	108	314	254
EC-10TW	10 gallons	inches	16	15	26	34.88	17.25	26.25	4.62	28	6.12	14.75	12.75
	38 litres	mm		381	660	886			117	711			
EC-12TW	12 gallons	inches	406	17	28	36.88	438	667	4.12	30	156	375	12.75
	45 litres	mm		432	711	937			105	762			

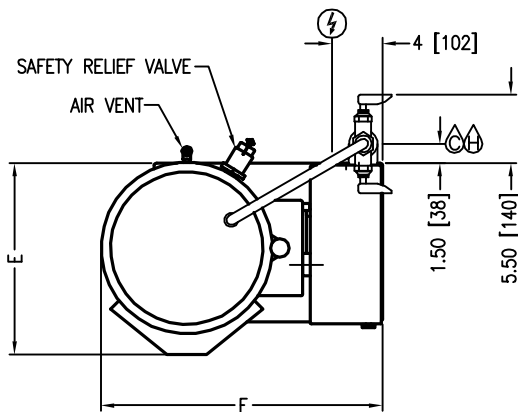

MODEL	SHIPPING WT.	MIN. CLEARANCE		
		R.H. SIDE	L.H. SIDE	BACK
EC-6TW	130 lbs. [59 kg]	0	3 [76]	2.50 [64]
EC-10TW	180 lbs. [82 kg]			2 [51]
EC-12TW	190 lbs. [86 kg]			2 [51]

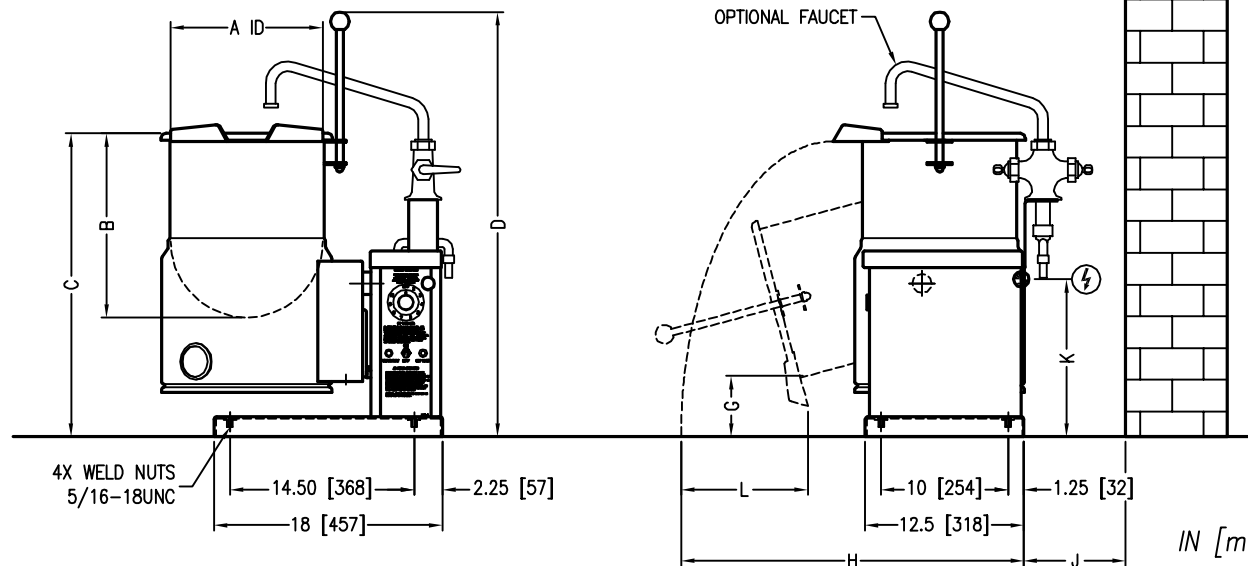

IN [mm]

7065R3

As continued product improvement is a policy of Crown, specifications are subject to change without notice.