















Turbofan E89MS Prover and Holding Cabinet

-  Dual proving and holding functions
-  Variable heat control
-  Variable humidity control
-  Robust stainless steel exterior for long life
-  Stainless steel door with full viewing window
-  Heavy duty stainless steel door handle
-  Stainless steel interior
-  Low velocity fan
-  Door condensate collection drawer
-  Castors as standard
-  240V 10A plug in connection
-  Field reversible door for line end positioning
-  8 tray capacity (460mm x 660mm)
-  Optional racking kit to suit gastronorm or 400mm x 600mm trays
-  Optional auto water fill



E89MS Prover and Holding Cabinet



Turbofan E89MS Prover and Holding Cabinet

MOFFAT

www.moffat.com.au

CONSTRUCTION

8 tray capacity
Stainless steel front and sides
Field reversible full view door
Full stainless steel door handle
Stainless steel racking system
Fully insulated
Stainless steel control panel with overlay
Door condensate collection drawer

CONTROLS

Off/Proof/Hold switch
Mechanical thermostat
Variable heat 0°C to 85°C
Variable humidity
Cabinet temperature thermometer

CLEANING AND SERVICING

Easy clean surfaces
Removable racking system
Removable water tank
Access to all controls from front panel
Full access side service panel
No tools required to replace lamps

OPTIONS

Auto water fill kit
Double stacking kit
Racking kit to suit gastronorm or 400mm x 600mm trays

SPECIFICATIONS

Electrical Requirements

220-240V, 50/60Hz, 1.7kW, 1P+N+E, 7.1A
10A cordset fitted

Water Connection (Auto water fill option)

R ³/₄ BSP thread
80psi max inlet pressure
20psi min inlet pressure

External Dimensions

Width 710mm
Height 900mm
Depth 810mm

Internal Dimensions

Width 480mm
Height 680mm
Depth 715mm

Nett Weight

85kg (187lbs)

Packing Data

140kg (309lbs)
0.75m³ (26.5ft³)
Width 750mm
Height 1015mm
Depth 945mm

Australia
Moffat Pty Limited

Victoria/Tasmania
740 Springvale Road
Mulgrave, Victoria 3170
Telephone 03-9518 3888
Facsimile 03-9518 3833
Email vsales@moffat.com.au
www.moffat.com.au

New South Wales
Telephone 02-8833 4111
Email nswsales@moffat.com.au

South Australia
Telephone 08-8274 2116
Email dmiller@moffat.com.au

Queensland
Telephone 07-3630 8600
Email qldsales@moffat.com.au

Western Australia
Telephone 08-9562 0263
Email jberent@moffat.com.au

New Zealand
Moffat Limited

Christchurch
Telephone 03-389 1007
Email sales@moffat.co.nz
www.moffat.co.nz

Auckland
Telephone 09-574 3150
Email sales@moffat.co.nz

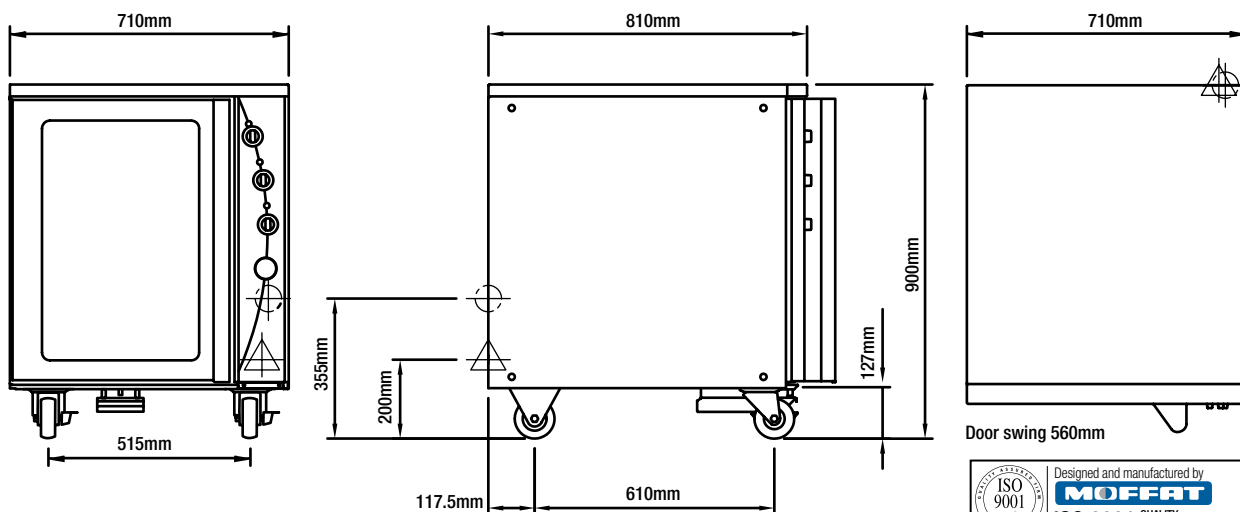

E89MS Prover and Holding Cabinet



ISO 9001

All Turbofan products are designed and manufactured by Moffat Ltd using the internationally recognised ISO 9001 quality management system, covering design, manufacture and final inspection, ensuring consistent high quality at all times.

