

# Turbofan E85-8 and E85-12 Provers

-  Full view door
-  Variable heat control
-  Variable humidity control
-  Stainless steel outer
-  Stainless steel inner
-  Low velocity fan
-  Castors as standard
-  110V plug in connection
-  Door removes for cleaning
-  Optional auto fill



E85-8



E85-12



# Turbofan E85-8 and E85-12

## Provers

### CONSTRUCTION

8 pan capacity (E85-8)  
12 pan capacity (E85-12)  
Stainless steel front and sides  
Removable full view door  
Strong and stylish handle  
Stainless steel racking system  
Fully insulated  
Enamel control panel

### CONTROLS

On/off switch  
Mechanical thermostat  
Variable heat 24°C to 40°C  
Variable humidity

### CLEANING AND SERVICING

Easy clean surfaces  
Removable racking system  
Removable water tank

### OPTIONS

Auto water fill kit

### SPECIFICATIONS

**Electrical Requirements**  
220-240V, 50Hz, 1.65kW, 1P+N+E, 7.2A

**Water** (autofill option)  
19mm (<sup>3</sup>/<sub>4</sub>" BSP thread  
80psi max inlet pressure  
20psi min inlet pressure

#### E85-8

##### External Dimensions

Width 880mm  
Height 902mm  
Depth 880mm

##### Internal Dimensions

Width 460mm  
Height 700mm  
Depth 660mm

##### Nett Weight

93kg (205lbs)

##### Packing Data

154kg (340lbs)  
1.06m<sup>3</sup> (37.4ft<sup>3</sup>)  
Width 970mm  
Height 1090mm  
Depth 1001mm

#### E85-12

##### External Dimensions

Width 880mm  
Height 1145mm  
Depth 880mm

##### Internal Dimensions

Width 460mm  
Height 945mm  
Depth 660mm

##### Nett Weight

120kg (265lbs)

##### Packing Data

181kg (399lbs)  
1.26m<sup>3</sup> (44.5ft<sup>3</sup>)  
Width 970mm  
Height 1300mm  
Depth 1001mm

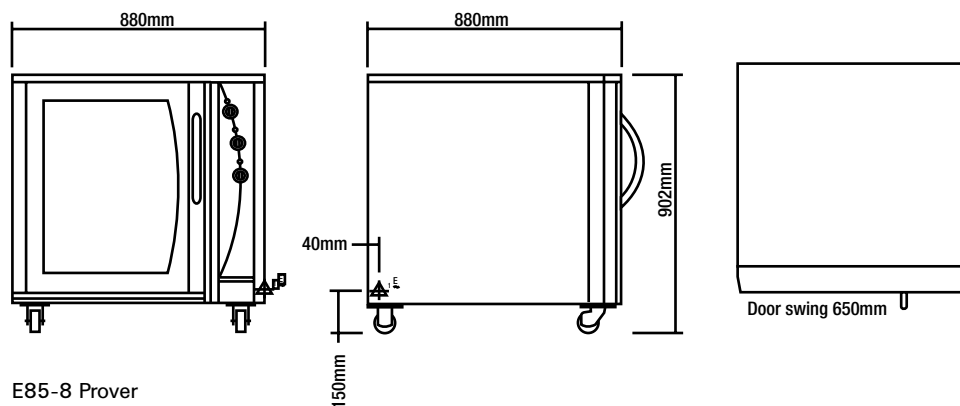

E85-8 Prover

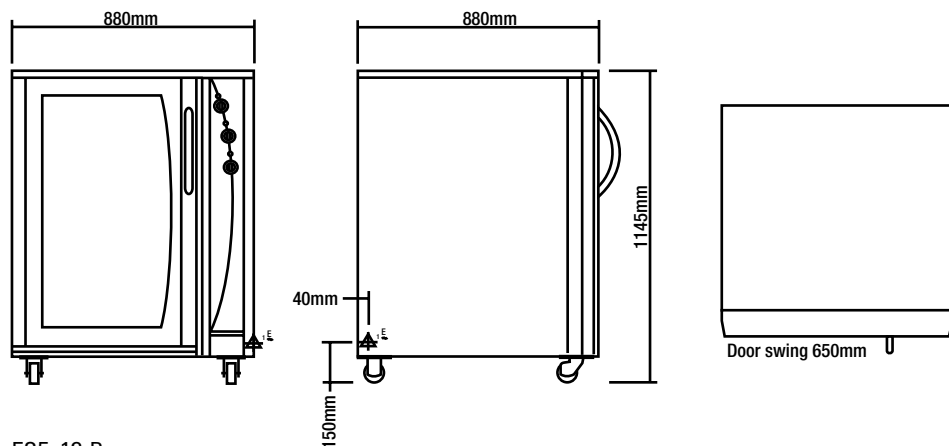

E85-12 Prover

**MOFFAT**

www.moffat.com.au

**Australia**  
Moffat Pty Limited

**Victoria/Tasmania**  
740 Springvale Road  
Mulgrave, Victoria 3170  
Telephone 03-9518 3888  
Facsimile 03-9518 3833  
Email vsales@moffat.com.au  
www.moffat.com.au

**New South Wales**  
Telephone 02-8833 4111  
Email nswsales@moffat.com.au

**South Australia**  
Telephone 08-8274 2116  
Email dmiller@moffat.com.au

**Queensland**  
Telephone 07-3630 8600  
Email qldsales@moffat.com.au

**Western Australia**  
Telephone 08-9305 8855  
Email jberent@moffat.com.au

**New Zealand**  
Moffat Limited

**Christchurch**  
Telephone 03-389 1007  
Email sales@moffat.co.nz  
www.moffat.co.nz

**Auckland**  
Telephone 09-574 3150  
Email sales@moffat.co.nz



**ISO 9001**  
All Turbofan products are designed and manufactured by Moffat Ltd using the internationally recognised ISO 9001 quality management system, covering design, manufacture and final inspection, ensuring consistent high quality at all times.

