

Technical data sheet for

ROBOT SEMI AUTOMATIC BDR 30 PIECE

Model Number DR2-4/30

- 30 round rolls per operation
- Conventional tilt head for cleaning (right to left)
- Rounding control front mounted
- Fitted standard with power isolation switch (side mounted)
- Quick release shroud for ease of cleaning
- Side hook for rounding plates (3 plates supplied with machine)



Overall Construction

- Extended base designed to protect machine from rack damage
- Heavy-duty steel fabricated body construction for durability and long life
- Machine base and body in two-pack paint finish
- Rounding head covers industrial plastic and easily removable for cleaning
- Fitted with nylon wheels as standard
- Teflon coated rounding head

Operation

- Manual pressing/degassing
- Rounding manually activated via front lever
- Finished roll weights determined by bulk dough placed on rounding plate
- Minimum recommended dough capacity per operation 900 grams

Note: Maximum recommended dough capacity per operation 3kg



Technical data sheet for

ROBOT SEMI AUTOMATIC BDR 30 PIECE

Model Number DR2-4/30

Machine Weight Range / Output

- Minimum weight range 30 grams
- Maximum weight range 100 grams
- Output approx 1800 rolls per hour

Specifications

- W 620mm x D 620mm x H 1460mm (without handle)
- 400 – 415V, 3P+N+E, 50Hz, 0.55kW
- 5 pin 10A plug supplied
- Weight 400kg

Additional Technical Information

- Head clearance from rounding table 85mm
- Power outlet to be located a minimum 1.5m off floor

Options

- Machines available with various weight ranges to suit specialized production needs

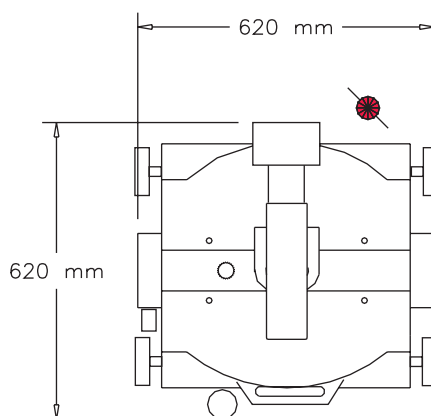
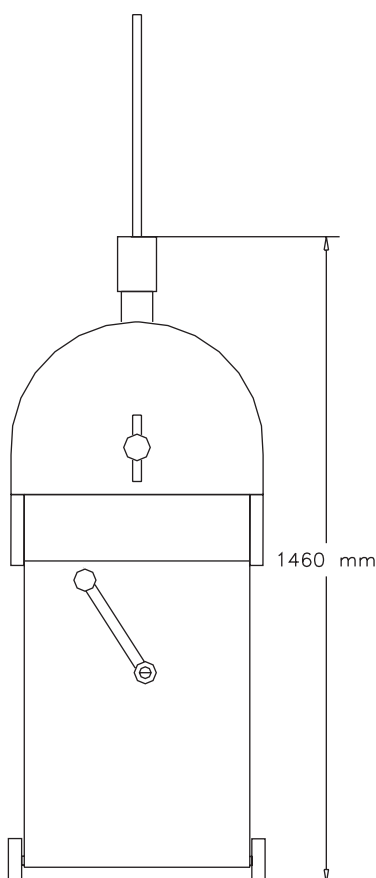

Australia
Moffat Pty Limited

Victoria / Tasmania
740 Springvale Rd
Mulgrave
Victoria 3170
Australia
Ph 03-9518 3888
Fax 03-9518 3833
Email vsales@moffat.com.au
www.moffat.com.au

New South Wales
Ph 02-8833 4111
Email nswsales@moffat.com.au
www.moffat.com.au

South Australia
Ph 03-9518 3888
Email vsales@moffat.com.au
www.moffat.com.au

Queensland
Ph 07-3630 8600
Email qldsales@moffat.com.au
www.moffat.com.au

Western Australia
Ph 08-9202 6820
Email bgarcia@moffat.com.au
www.moffat.com.au

New Zealand
Moffat Limited

Christchurch
16 Osborne Street
Christchurch 8011
New Zealand
Ph 03-389 1007
Fax 03-389 1276
Email sales@moffat.co.nz
www.moffat.co.nz

Auckland
Ph 09-574 3150
Email sales@moffat.co.nz
www.moffat.co.nz



In line with policy to continually develop and improve its products, Moffat Limited reserves the right to change specifications and design without notice.

Printed in China
© Copyright Moffat Ltd

Moffat/6244/BH/2.08

