

Technical data sheet for

ROBOT FULLY AUTOMATIC BDR 30 PIECE

Model Number DR-ROBOT0T2 4/30A

- 30 round rolls per operation
- Special front swivel head design for efficient and safe cleaning
- Pressing and rounding functions fully automatic
- Controls incorporate 6 programmable settings (front mounted)
- Fitted standard with power isolation switch (side mounted)
- Quick release shroud for ease of cleaning
- Side hook for rounding plates (3 plates supplied with machine)



Overall Construction

- Extended base designed to protect machine from rack damage
- Heavy-duty steel fabricated body construction for durability and long life
- Machine base and body in two-pack paint finish
- Rounding head covers industrial plastic and easily removable for cleaning
- Fitted with nylon wheels as standard
- Teflon coated rounding head

Operation

- Automatic pressing/degassing
- Rounding function automatic
- Two button operation for operator safety
- Finished roll weights determined by bulk dough placed on rounding plate
- Maximum recommended dough capacity per operation 3kg

Note: Maximum dough capacity of machine can vary depending on condition of dough and strength of flour being used



Technical data sheet for

ROBOT FULLY AUTOMATIC BDR 30 PIECE

Model Number DR-ROBOT0T2 4/30A

Machine Weight Range / Output

- Minimum weight range 30 grams
- Maximum weight range 100 grams
- Output approx 1800 rolls per hour

Specifications

- W 620mm x D 620mm x H 1750mm
- 400 – 415V, 3P+N+E, 50Hz, 1.3kW
- 5 pin 10A plug supplied
- Weight 400kg

Additional Technical Information

- Head clearance from rounding table 85mm
- Power outlet to be located a minimum 1.5m off floor

Options

- Machines available with various weight ranges to suit specialized production needs

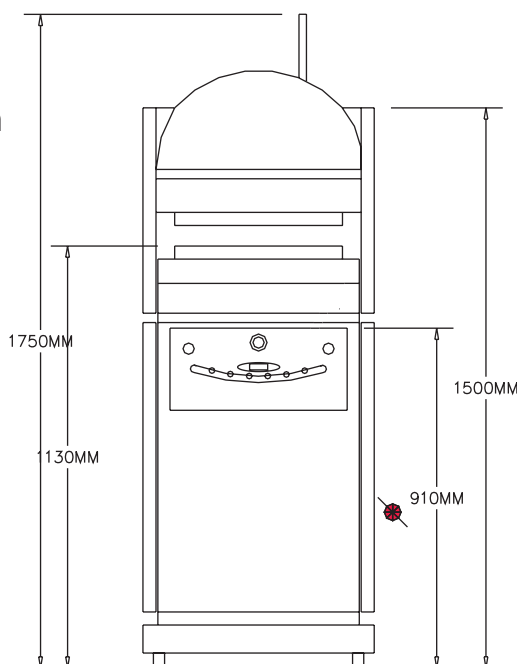
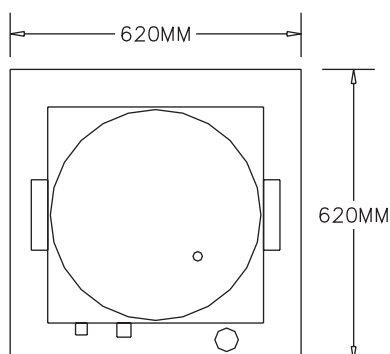

Australia
Moffat Pty Limited

Victoria / Tasmania
740 Springvale Rd
Mulgrave
Victoria 3170
Australia
Ph 03-9518 3888
Fax 03-9518 3833
Email vsales@moffat.com.au
www.moffat.com.au

New South Wales
Ph 02-8833 4111
Email nswsales@moffat.com.au
www.moffat.com.au

South Australia
Ph 03-9518 3888
Email vsales@moffat.com.au
www.moffat.com.au

Queensland
Ph 07-3630 8600
Email qldsales@moffat.com.au
www.moffat.com.au

Western Australia
Ph 08-9202 6820
Email bgarcia@moffat.com.au
www.moffat.com.au

New Zealand
Moffat Limited

Christchurch
16 Osborne Street
Christchurch 8011
New Zealand
Ph 03-389 1007
Fax 03-389 1276
Email sales@moffat.co.nz
www.moffat.co.nz

Auckland
Ph 09-574 3150
Email sales@moffat.co.nz
www.moffat.co.nz



In line with policy to continually develop and improve its products, Moffat Limited reserves the right to change specifications and design without notice.

Printed in China
© Copyright Moffat Ltd

Moffat/6244/BH/2.08

