



# EVOLUTIONSERIES

INSTALLATION AND OPERATION MANUAL

## ELECTRIC SALAMANDER

E91  
E91B



Date Purchased	_____
Serial Number	_____
Dealer	_____
	_____
Service Provider	_____
	_____

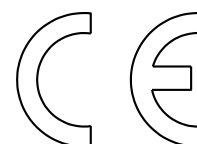

For use in GB & IE

227956-4

---

**MANUFACTURED BY**

Moffat Limited  
PO Box 10001  
Christchurch  
New Zealand  
Ph: (03) 389 1007  
Fax: (03) 389 1276

**WORLD-WIDE BRANCHES****UNITED KINGDOM**

Blue Seal  
67 Gravelly Business Park  
Gravelly Park  
Birmingham  
West Midlands  
B24 8TQ  
Ph: (121) 327 5575  
Fax: (121) 327 9711

**UNITED STATES**

Moffat Inc  
3765 Champion Blvd  
Winston-Salem  
North Carolina 27115  
Ph: (336) 661 0257  
Fax: (336) 661 9546

**CANADA**

Serve Canada  
22 Ashwarren Road  
Downview  
Ontario M3J1Z5  
Toll Free:800 263 1455  
Ph: (416) 631 0601  
Fax: (416) 631 0315  
info@servecanada.com  
www.servecanada.com  
www.moffat.com

**NEW ZEALAND****Christchurch**

Moffat Limited  
PO Box 10-001  
16 Osborne Street  
Christchurch  
Ph: (03) 389 1007  
Fax: (03) 389 1276

**Auckland**

Moffat Limited  
4 Waipuna Road  
Mt Wellington  
Auckland  
Ph: (09) 574 3150  
Fax: (09) 574 3159

**AUSTRALIA****Victoria New South Wales**

Moffat Pty Limited  
740 Springvale Road  
Mulgrave, Melbourne  
Victoria 3171  
Ph: (03) 9518 3888  
Fax: (03) 9518 3838

Moffat Pty Limited  
3/142 James Ruse Drive, Rose Hill  
PO Box 913, Smithfield  
Sydney, N.S.W. 2142  
Ph: (02) 8833 4111  
Fax: (02) 8833 4133

**Western Australia**

Moffat Pty Limited  
67 Howe Street  
Osbourne Park  
WA 6017  
Ph: (08) 9202 6820  
Fax: (08) 9202 6836

**Queensland**

Moffat Pty Limited  
30 Prosperity Place  
Geebung, Brisbane  
Queensland 4034  
Ph: (07) 3630 8600  
Fax: (07) 3630 8623

The reproduction or copying of any part of this manual by any means whatsoever is strictly forbidden unless authorized previously in writing by the manufacturer.

In line with policy to continually develop and improve its products, Moffat Ltd. reserves the right to change the specifications and design without prior notice.

**E91 ELECTRIC SALAMANDER (Branding Plate Optional)**

**E91B ELECTRIC SALAMANDER (With Branding Plate)**

<b>Introduction .....</b>	<b>2</b>
<b>Specifications .....</b>	<b>3</b>
Model Numbers Covered in this Specification	
General	
Electrical Supply Requirements	
Dimensions	
Weight	
<b>Installation .....</b>	<b>5</b>
Installation Requirements	
Unpacking	
Location	
Clearances	
Wall Mounting (to non-combustible wall only)	
Electrical Connection	
Commissioning	
<b>Operation.....</b>	<b>9</b>
Operation Guide	
Description of Controls	
Operating the Controls	
Racking	
Cooking Recommendations	
<b>Cleaning and Maintenance .....</b>	<b>11</b>
General	
Racking	
Stainless Steel Surfaces	
Vitreous Enamel Surfaces	
Trough Tray	
<b>Fault Finding.....</b>	<b>12</b>
<b>Circuit Diagram .....</b>	<b>13</b>
<b>Replacement Parts List .....</b>	<b>14</b>

---

## Introduction

---

We are confident that you will be delighted with your BLUE SEAL Electric Salamander, and it will become a most valued appliance in your commercial kitchen.

To ensure you receive the utmost benefit from your new unit, there are two important things you can do.

### Firstly

Please read the instruction book carefully and follow the directions given. The time taken will be well spent.

### Secondly

If you are unsure of any aspect of the installation, instructions or performance of your Salamander, contact your BLUE SEAL dealer promptly. In many cases, a phone call could answer your questions.

### CE Only:

These instructions are only valid if the country code appears on the appliance. If the code does not appear on the appliance, refer to the supplier of this appliance to obtain the technical instructions for adapting the appliance to the conditions for use in that country.

### **WARNING:**

**GREAT CARE MUST BE TAKEN BY THE OPERATOR TO USE THE EQUIPMENT SAFELY TO GUARD IT AGAINST RISK OF FIRE.**

- **THE APPLIANCE MUST NOT BE LEFT ON UNATTENDED.**
- **IT IS RECOMMENDED THAT A REGULAR INSPECTION IS MADE BY A COMPETENT SERVICE PERSON TO ENSURE CORRECT AND SAFE OPERATION OF YOUR APPLIANCE IS MAINTAINED.**

### **WARNING:**

**DO NOT STORE OR USE GASOLINE OR OTHER FLAMMABLE VAPOURS OR LIQUIDS IN THE VICINITY OF THIS OR ANY OTHER APPLIANCE.**

**DO NOT SPRAY AEROSOLS IN THE VICINITY OF THIS APPLIANCE WHILE IT IS IN OPERATION.**

### **WARNING:**

**IMPROPER INSTALLATION, ADJUSTMENT, ALTERATION, SERVICE OR MAINTENANCE CAN CAUSE PROPERTY DAMAGE, INJURY OR DEATH. READ THE INSTALLATION, OPERATING AND MAINTENANCE INSTRUCTIONS THOROUGHLY BEFORE INSTALLING OR SERVICING THIS APPLIANCE.**

### **CAUTION:**

**This appliance is for professional use and is only to be used by qualified people**

### Model Numbers Covered in this Specification

**E91 Electric Salamander (Branding Plate Optional)**

**E91B Electric Salamander with Branding Plate.**

### General

A commercial heavy duty, wall or bench mounted electric fired infra-red grilling Salamander for a wide range of foods.

Blue Seal Salamanders feature independently controlled heat zones for left and right side of the cooking area.

Two efficient high speed infrared elements in the ceiling of the cavity are independently operated with the left and right hand side controls of the appliance.

Each element has LO,MED, HI settings to provide full cooking flexibility.

E91 Rack supports have 4 fixed height positions offering flat and angled rack positioning. Rack can be changed from flat to angled position by partial removal of rack. Rack height must be fully removed for repositioning of rack height setting. Branding Plate is available as an accessory item. Refer to Replacement Parts List.

E91B Rack supports have 4 fixed height positions offering flat and angled rack positioning. Rack can be changed from flat to angled position by partial removal of rack. Rack height must be fully removed for repositioning of rack height setting. Supplied with Branding Plate.

Branding Plates are available as an accessory item. The cast Aluminium branding plates provide a deep grooved / ribbed surface and can be used with this racking system.

The Branding Plates are fitted onto the standard wire rack allowing ease of change as required between menus.

Blue Seal Salamanders come standard with a trough tray incorporating a front grease trough for direct collection of cooking grease from Branding Plate operation.

The tray is easily removed (slide out) for cleaning and to provide easy cleaning access to rear and sides of cooking area.

### Electrical Supply Requirements

220-240 Volt, 50/60 Hz, 1 P+N+E, 6.0kW @ 240V, 25A.

## Specifications

---

### Dimensions:

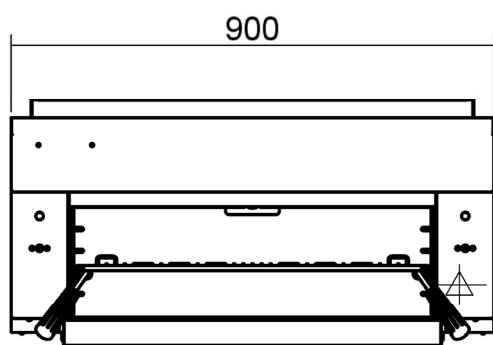

Front

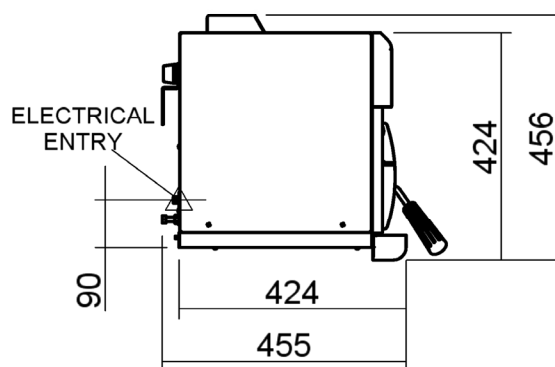

Side

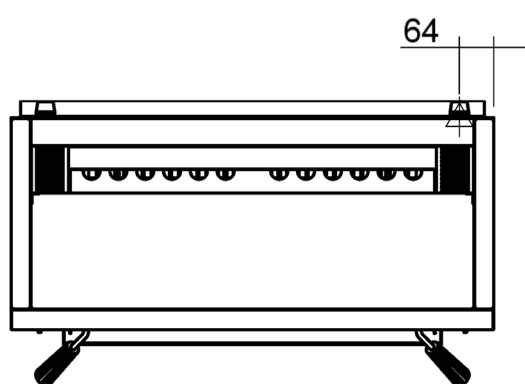

Plan

### Internal Dimensions

Width	685 mm.
Height	230 mm (at front).
Depth	330 mm.

### Cooking Area

Rack	610mm x 310mm.
Branding Plate (Accessory)	610mm x 310mm.

### Weight (Nett)

41kg (without Branding Plate or Racking System).

## Installation Requirements

**NOTE: It is most important that this salamander is installed correctly and that operation is correct before use. Installation shall comply with local electrical, health and safety requirements.**

Blue Seal Salamanders are designed to provide years of satisfactory service, and correct installation is essential to achieve the best performance, efficiency and trouble-free operation.

This appliance must be installed in accordance with National installation codes and in addition, in accordance with relevant National / Local codes covering electrical and fire safety.

<b>Australia / New Zealand</b>	<b>AS/NZS3000</b>	- Wiring Rules.
<b>United Kingdom:</b>	<b>BS 7671</b>	- Requirements for Electrical Installations.

**Installations must be carried out by authorised persons only. Failure to install equipment to the relevant codes and manufacturer's specifications shown in this section will void the warranty.**

## Unpacking

1. Remove all packaging and transit protection from the appliance including all protective plastic coating from the exterior stainless steel panels.
2. Check equipment and parts for damage. Report any damage immediately to the carrier and distributor.
3. Check that the following parts have been supplied with the Salamander:

1 x Salamander Rack.	1 x Wall Mounting Bracket, including;
1 x Crumb Tray.	- 2 x 25mm Black Plastic Spacers.
	- 2 x $\frac{3}{8}$ " Bolts / Nuts.
4. Report any deficiencies to the distributor who supplied the unit.
5. Check that the available electrical supply is correct to that shown on the rating plate located on the front bottom corner of the right hand side panel.

## Location

1. This appliance must be mounted onto a non-combustible wall or tailored stand, using the rear wall bracket and spacing screws provided.
2. Combustible walls must not protrude past the front of the appliance.
3. This appliance must not be mounted on a combustible surface or metal surface, as radiated heat will cause these surfaces to become extremely hot.
4. Caution should be taken as intense heat is emitted at the bottom front of the appliance.
5. The unit should be mounted under an extraction hood in compliance with all local regulations.

**In the event that the unit is not mounted under an extraction hood, the installer must ensure that all regulations are met and that there is an unobstructed minimum distance of 750 mm from the top surface of the unit to the ceiling, which must be of non-combustible material.**

**NOTE: Do not obstruct or block the appliances flue. Never directly connect a ventilation system to the appliance flue outlet.**

# Installation

## Clearances

This unit must be installed on a non-combustible wall or tailored stand with the following clearances:-

	Combustible Surface	Non-Combustible Surface
Left/Right hand side	50mm	0mm
Rear	50mm	0mm

Top Clearance to;	
Extraction Hood	200mm
Grease Arresting Filter	600mm
Ceiling (subject to all local regulation requirements)	300mm

**NOTE: Top clearances can be reduced where local fire protection system is provided, if allowed by the local regulations.**

## Wall Mounting (to non-combustible wall only)

**NOTE: Only non-combustible materials can be used in close proximity to this appliance.**

1. Fix the wall mounting bracket to the wall with six screws, in such a position that the top of the bracket is level and at least 945 mm (38") above any surface beneath the unit. This will ensure that the bottom of the Salamander is at least 600 mm (24") above any surface.
2. Fit the two black plastic spacers to the top rear corners of the unit. Leave them unscrewed by approximately 5 mm.
3. Fit the two adjusting screws / bolts into the nutserts at the bottom rear corners of the unit. These should protrude approximately 30 mm from the rear of the Salamander.
4. Lift the Salamander onto the wall bracket, lining up the black plastic spacers on the salamander with the mounting notches in the bracket.
5. Lower the Salamander onto the mounting bracket.
6. Tighten the black spacers securely and adjust the levelling screws/bolts to ensure that the unit is level.

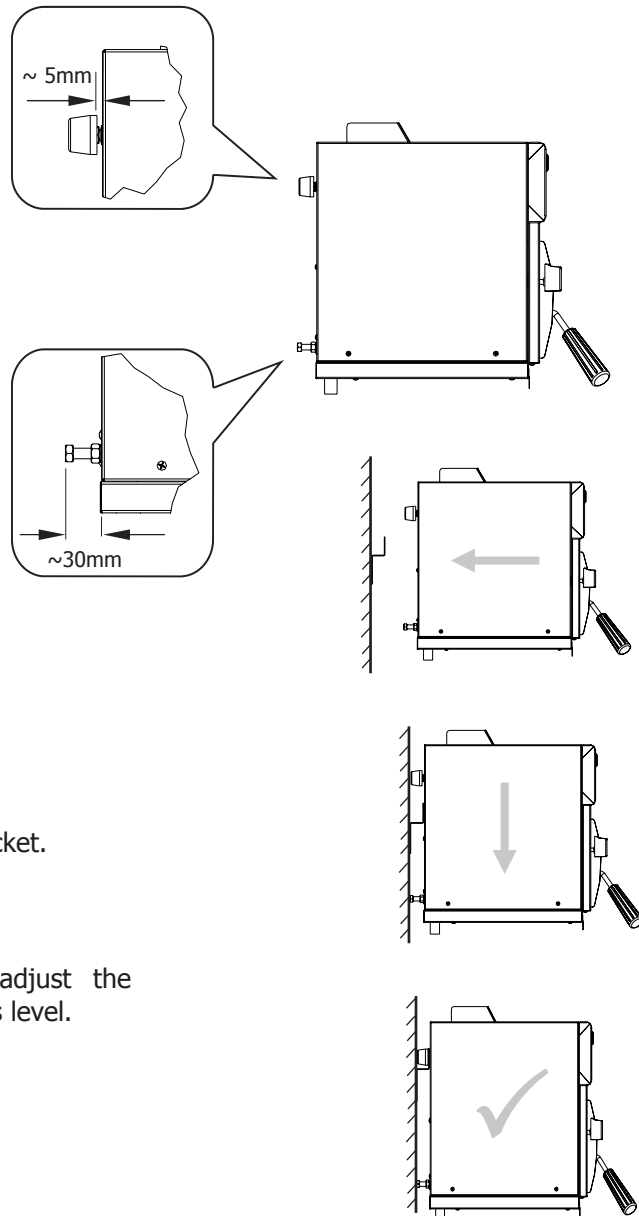

## Electrical Connection

### **WARNING:**

**THIS APPLIANCE MUST BE EARTHED. IF THE SUPPLY CORD IS DAMAGED, IT MUST BE REPLACED BY A SUITABLY QUALIFIED PERSON IN ORDER TO AVOID A HAZARD.**

When connecting a Blue Seal electric appliance to the main supply, ensure that the following is carried out:-

- An isolating switch is fitted within 2 m of the appliance, but not on the appliance and in such a position that the user does not have to reach across the cooking surface.
- Supply cord shall be oil-resistant, sheathed flexible cable and not lighter than ordinary polychloroprene or other equivalent synthetic elastomer sheathed cord (as per AS/NZS 3191 part 2.10.11. or IEC 60245-IEC-57) e.g. HO5 RN-F Type.
- The branch supply line shall be individually overload protected to the correct current rating and the supply chord shall be protected against any mechanical or thermal damage.
- A grommet is fitted around the wiring entry hole into the appliance.
- All wiring connections must be tight.

Refer to the appropriate wiring standards for the size of cable that is to be supplied to an appliance for the current drawn on that line.

### **NOTE: ALL ELECTRICAL CONNECTIONS MUST ONLY BE CARRIED OUT BY AN AUTHORISED PERSON.**

1. Remove either the left or right hand side panel to allow access to the electrical connection terminal block. Fit the cable through the small grommet located at the rear of the unit and connect to the terminals as marked.
2. If required, the appliance can be connected to two 13 or 15 amp single phase supplies by removing the insulated wire loom between the left and right hand terminal blocks. Independent supplies can then be connected to each side.
3. The operating voltage of the salamander is stated on the rating plate affixed to the right hand side panel front bottom corner. This information is also shown in the "Specifications" Section of this manual. Ensure that the available voltage is correct.



### **NOTE:**

- **This appliance must be grounded / earthed.**
- **Fixed wiring installations must incorporate an all-pole disconnection switch.**

## Commissioning

1. Before leaving the new installation, check that all the connections are correct and, and that the unit functions in accordance with the operating instructions.
2. Check the current draw and loading for the equipment. Refer specification section for correct electrical requirements.

### **NOTE:**

- **If for some reason it is not possible to get the unit to operate correctly, turn off the electrical power supply and contact a qualified service person. The supplier of this unit will be able to recommend a suitable person.**
- **Make sure that the electrical supply is turned off before any service or maintenance work is carried out.**

# Operation

## Operation Guide

### **CAUTION:**

- **This appliance is for professional use and is only to be used by qualified people.**
- **Only authorised service persons should be used to carry out installation or servicing operations.**

1. The Blue Seal Salamanders have been designed to provide simplicity of operation and 100% safety protection.
2. Improper operation is therefore almost impossible, however bad operation practices can reduce the life of the salamander and produce a poor quality product. To use this salamander correctly please read the following sections carefully.

### **Description of Controls**

The salamander has individual heat controls for the left and right sides. Select the desired heat level and allow a few minutes for the elements to heat up.

- Blue Seal salamanders provide two independently controlled heat zones.
- High speed grilling is provided by the two high speed infrared elements in the ceiling of the grilling compartment.
- The left hand control knob and right hand control knob operate the left side and right side elements respectively, independently of each other.

### **E91 Salamander.**

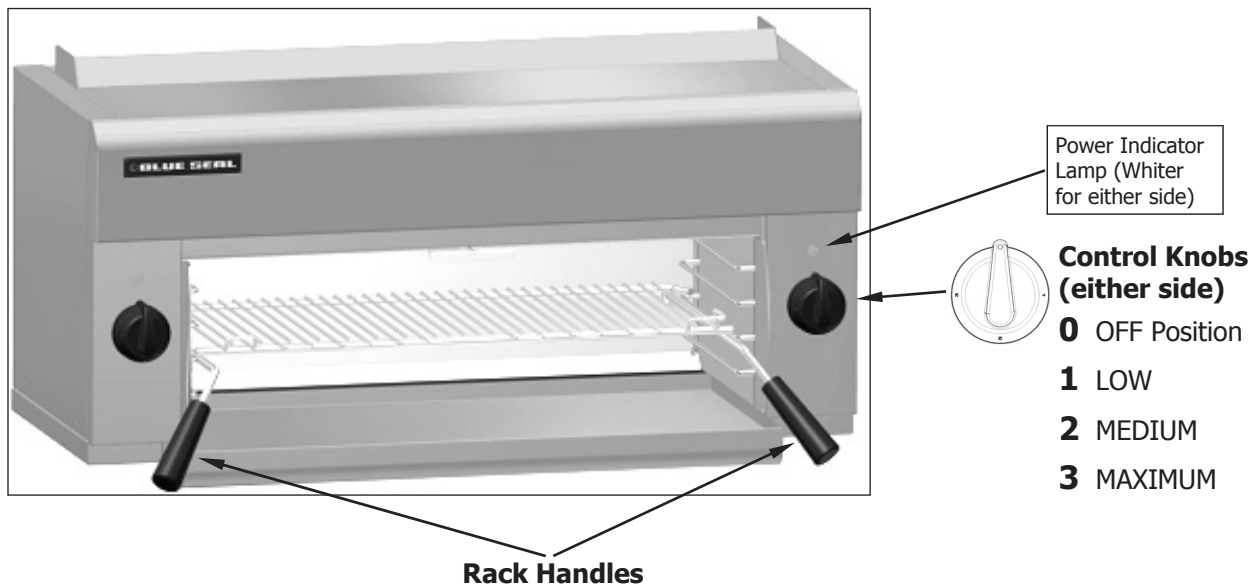

## Operating the Controls

### Turning on the Elements to the LOW Position

1. Check that the electrical supply is turned on. The power indicator neon will illuminate when power is turned 'ON'.
2. Turn the left control knob to the first position marked with a '1'.
3. The element will heat up to the LOW setting.
4. Repeat **Items 2 to 3** above with the right control knob to heat up the right hand element to the same setting.

### Turning the Elements to the MEDIUM Position

1. Turn the left control knob to the second position marked with a '2'.
2. The element will now heat to the MEDIUM setting.
3. Repeat **Items 1 to 2** above with the right control knob to heat up the right hand element to the same setting.

### Turning the Elements to the HIGH Position

1. Turn the left control knob to the third position marked with a '3'.
2. The element will now heat to the HIGH setting.
3. Repeat **Items 1 to 2** above with the right control knob to heat up the right hand element to the same setting.

### Turning the Elements to the OFF Position

1. Turn the left control knob to the off position marked with a '0'.
2. The element should now turn off.
3. Repeat **Items 1 to 2** above with the right control knob to turn off the right hand element.

## Racking

The Standard Rack System fitted to the Salamander is self-supporting when withdrawn, to allow easy loading of food. The installation of the rack is dependant on the cooking function required.

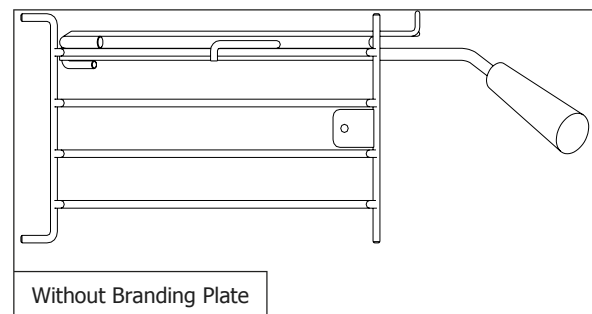
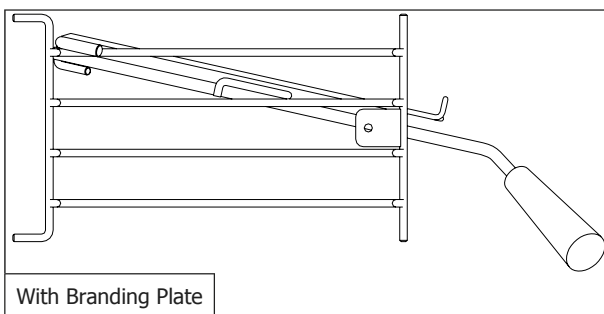

## Operation

---

### Cooking Recommendations

**CAUTION:**

**Do not leave the Salamander unattended when in use, as it does cook fast.**

1. This equipment has been designed to give a good evenness of heat across the rack area, so toasting, cheese melting and grilling should be relatively even wherever food is placed.
2. Position '**3**' (Maximum) is recommended for most grilling, cheese melting functions and position '**1**' (Low) for a reduced heat.
3. For cooking food through rather than just surface browning, rack position three and four from the top is recommended.
4. With the Branding Plate fitted, the unit is able to aid the chef in its ability to produce "medium rare" steaks in the front and "well done" steaks at the rear - achieved with the sloped Branding Plate rack position. (Shelf 2 and 3 from the top.).
5. Heating the Branding Plate under the burners before cooking commences, also allows the "sealed in flavoured goodness" to be achieved.

## Cleaning and Maintenance

---

### **CAUTION:**

**Always turn off the power supply before cleaning.**

**This unit is not water proof.**

**Do not use water jet spray to clean interior or exterior of this unit.**

### **General**

- To achieve the best results, cleaning must be thorough, and all controls and mechanical parts checked and adjusted periodically by a competent serviceman. If any small faults occur, have them attended to promptly.
- Don't wait until they cause a complete breakdown.

### **Racking**

- For ease of cleaning of this unit and the racking system and to achieve the best results, it is recommended that the racking is removed completely from the unit and cleaned independently. This will allow for a more thorough cleaning of the Salamander.
- To remove the racking system, carry out the following instructions.
  1. Remove the Grease / Crumb Tray from the underside of the salamander unit.
  2. Remove the Branding Plate from the rack (If fitted).
  3. Slide the rack out of the side racks and remove from the unit.
  4. Remove the left and right hand side racks from the unit by removing the single securing screw from each of the side racks.
  5. Withdraw the left and right hand side racks from the unit.
  6. Refit the racking in the reverse order once cleaning has been completed.

### **Stainless Steel Surfaces**

- Clean with detergent. Baked on deposits or discolouration may require a good quality stainless steel cleaner or stainless steel wool. Always apply the cleaner when the Salamander is cool and rub in the direction of the "grain".

### **Vitreous Enamel Surfaces**

- Do not use wire brushes, steel wool or other abrasive material. Clean the enamelled surfaces regularly with a good quality domestic oven cleaner. Remove the rack and side racks from the Salamander - this allows easy cleaning of the flat enamelled side walls. Leave the tray in to collect all residue.

### **Trough Tray**

- Empty and clean daily.

## Fault Finding

---

This section provides an easy reference guide to the more common problems that may occur during the operation of your equipment. The fault finding guide in this section is intended to help you correct, or at least accurately diagnose problems with your equipment.

Although this section covers the most common problems reported, you may encounter a problem not covered in this section. In such instances, please contact your local authorised service agent who will make every effort to help you identify and resolve the problem. Please note that the service agent will require the following information:-

- **The Model Trade Name and the Serial Number of the Appliance. (both can be found on the Technical Data Plate located on the appliance.**

<b>Fault</b>	<b>Possible Cause</b>	<b>Remedy</b>
The unit does not operate. (Neither element working).	The mains isolating switch on the wall, circuit breaker or fuses are "off" at the power board.	Turn "On".
One element does not work on all 3 settings.	Selector switch or element faulty.	Call service provider.

Circuit Diagram

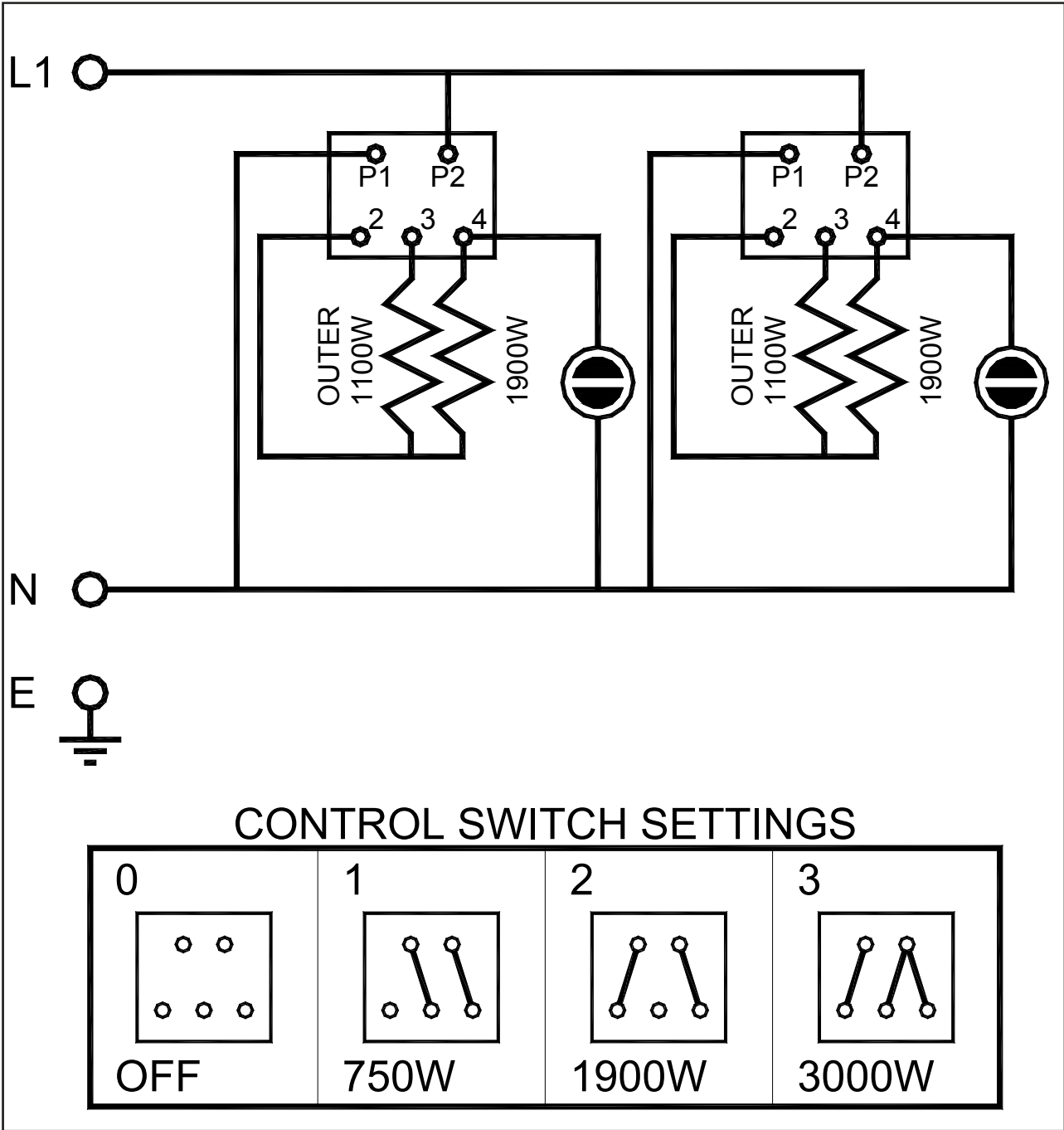

## Replacements Parts List

---

### Replacement Parts List

**IMPORTANT:**

Only genuine authorized replacement parts should be used for the servicing and repair of this appliance. The instructions supplied with the parts should be followed when replacing components.

For further information and servicing instructions, contact your nearest authorized service branch (contact details are as shown on the reverse of the front cover of this manual).

When ordering spare parts, please quote the part number and the description as listed below. If the part required is not listed below, request the part by description and quote model number and serial number which is shown on the rating plate.

#### Controls

017682	Selector Switch.
227394	Selector Knob.
026088	Element 3kW.
228922	Neon Indicator (White).

#### General

017963	Rack.
013395	Rack Handle.
026093	Side Rack.
227950	Trough Tray.
013418	Branding Plate.
227961	Side Rack Screw.
013908	Spacer Foot.
026096	Wall Mounting Bracket.

#### Accessories (Optional)

013418	Branding Plate (Australia Only).
--------	----------------------------------

